

FLANGE MOUNT PUMPS (SIDEWALL)



OPERATION AND MAINTENANCE INSTRUCTIONS

DESCRIPTION & OPERATING CHARACTERISTICS:

These pumps are designed for liquids of relatively light viscosity. The maximum viscosity for larger pumps of 1/8 HP or more, is 500 SSU; except for the 200 Series which is 2200 SSU. Special models may operate at a higher viscosity if the horsepower is sufficient.

Flange Mount pumps have a side intake and liquid is drawn in through the intake and discharged at relatively low pressure. The top of the impeller must be covered to assure satisfactory pumping. Maximum liquid level is 1" below the bottom of the motor, except for sealed models (BSWS, CSWS, DSWS, ESWS) which may be mounted below liquid level. Minimum liquid level is 1" above upper pump intake.

Centrifugal pumps will deliver a large volume of liquid at low pressure. The flow rate is influenced greatly by viscosity or restrictions such as small piping and numerous fittings. It is advisable to use pipe or hose of the same size as the pump discharge and, if restrictions must be made, do so as close to the point of application as possible. Needle and globe type valves greatly restrict the flow. Gate valves or other types with wide opening and minimum restrictions are recommended. A street "EL" also offers unusual resistance and should not be used.

Centrifugal pumps of this type will handle a relatively large amount of foreign material without damage to the pump, because there are no seals or bearings in the liquid. If sediment is allowed to build up around the lower portion of the pump, the impeller housing will become clogged and binding may occur which can damage the motor and/or the impeller. Where substantial quantities of foreign material will be present and may settle out, make sure the pump is mounted well off the bottom and baffled to prevent this accumulation around the impeller.

Graymills Centrifugal pumps may be throttled to provide whatever flow is required and there is no need for a bypass or relief valve. The pump will use less horsepower as flow is reduced.

MAXIMUM VISCOSITY RANGE FOR "SAFE" OPERATION

The maximum viscosities given above are recommended for standard pumps, however, special Centrifugals with higher horsepower may be used for higher viscosities. If the viscosity is too heavy, the motor will be overloaded and will burn out unless overload protection has been installed. Overload protection is recommended.

Pumps will deliver less flow as the viscosity increases. Temperature may affect viscosity. A viscosity of 100 SSU oil, for example, may increase substantially as it gets colder.

Pumps with rotary air motors cannot be overloaded but will merely slow down or stall if viscosity is too heavy or if binding occurs.

TEMPERATURE LIMITATIONS

Graymills Flange Mount pumps feature GM2GG plastic impellers and can be used with temperatures up to 180°F. Maximum ambient temperature for electric motors is 40°C (104°F).

Modifications of standard pumps can be made so that the motor is protected. Consult the factory on such applications.

ELECTRICAL CONNECTIONS

ALL PUMP MOTORS MUST BE GROUNDED, WE RECOMMEND A FUSE TRON BE USED IN THE CIRCUIT WITH UP TO 10% GREATER AMPERAGE THAT INDICATED ON THE MOTOR NAMEPLATE.

Check the name plate on the pump and be sure it corresponds to the electrical current being used. Also check the direction of rotation to make sure it is wired to run in a counter-clock wise direction looking down on the top of the motor. (This for 3-phase motors only.)

For 3-phase motors, the standard electrical rating is 230/460 Volt, 60 HZ and 190/380 Volt, 50 HZ.

Standard, totally enclosed, or open motors cannot be used in hazardous locations or liquids. Graymills can provide explosion proof motors for such purposes.

WHAT DETERMINES "HEAD"

The "head" against which a pump operates is made up of the total resistance, resulting from (1) fittings, valves, and other restrictions, (2) the resistance created by friction in the pipe and resulting from internal friction caused by flow rate and the viscosity of the liquid, (3) the height to which the liquid must be raised. "Head" does not mean merely height. 10' head equals 4.3 PSI.

PUMP DISASSEMBLY (SEE FACING PAGE EXPLODED VIEW FOR REFERENCED ITEMS)

NOTE: *The following procedure assumes pump disassembly will be done with the pump attached to a tank. Only disassemble to accomplish a required repair.*

1. Remove six cap screws (1) and lock washers (2).
2. Lift motor (3), complete with pump parts (5 thru 20), straight up and out of pump housing (21).

CAUTION: Insert (13) is a rather precise fit in the bore of housing (21), requiring the assembly to basically remain vertical until fully separated from the housing so as not to incur damage to pump components.

3. Remove and discard gasket (4).

NOTE: For easy pump disassembly, stand removed assembly upside down on motor's end and proceed as follows.

4. Remove cotter pin (5) and discard. Remove castle nut (6), shim(s) (7), if used, and flat washer (8).
5. Remove impeller (9), flat washer (10), spring (12), and insert (13). On sealed model pumps remove impeller (9), flat washer (10), shim washers (11), seal kit (12A) and insert (13).

NOTE: *Record washer and shim sizes, quantities, and placement, as mentioned in steps 4 & 5 above, for correct reassembly.*

CAUTION: Incorrect shim/washer installation can cause impeller (9) to bind against housing (21) or insert (13), causing poor pump operation and impeller damage.

NOTE: Seal kit (12A) is a press fit into insert (13). To remove kit, place insert, with kit ceramic part facing up, on a flat surface which has an opening large enough to accept seal kit diameter. Place two flat blade screwdrivers against ceramic and press seal kit out of insert.

6. Remove four cap screws (14) and lock washers (15) and lift off column assembly (16).
7. Loosen two set screws (17) and remove pump impeller shaft (18) from coupling (20).
8. Loosen two set screws (19) and remove coupling (20) from motor's shaft.

PUMP REASSEMBLY

NOTE: For pump reassembly procedures, reverse the order of disassembly as described in steps 6 thru 8 above. Install insert (13) and spring (12). On sealed model pumps install insert (13) and seal kit (12A).

1. Install shims (11), if used, and flat washer (10), in order and quantity as noted during disassembly. Install impeller (9).

NOTE: Impeller has embossed words "TOP" and "BOTTOM" to assist in assembly. "TOP" of impeller faces motor and "BOTTOM" faces housing.

2. Install flat washer (8), shims (7), if used, in order and quantity as noted during disassembly.
3. Thread impeller castle nut (6) onto pump impeller shaft (18) until tight.

CAUTION: Rotate impeller (9) by hand, ascertaining that it will run freely, with ample clearance between it and insert (13) or housing (21). If not, adjust impeller position by removing and/or adding shims (either 7 or 11).

4. Replace cotter pin (5) and gasket (4).
5. Install motor and pump assembly (3) by lowering it onto housing (21). Secure with six lock washers (2) and cap screws (1).

NOTE: Coat cap screw (1) threads with an RTV silicone sealant or equivalent.

PUMP FLANGE REMOVAL

1. Remove four nuts (22) and pull motor & pump assembly, with housing (21), from flange (25).
2. Remove and discard housing gasket (23).
3. Remove four studs (24) from flange and pull flange (25) from reservoir.
4. Remove and discard gasket (26).

PUMP FLANGE INSTALLATION

NOTE: For pump flange installation procedures, reverse the order of removal as described in steps 1 thru 4 above, replacing gaskets (23 & 26)

FLANGE MOUNT PUMP EXPLODED VIEW

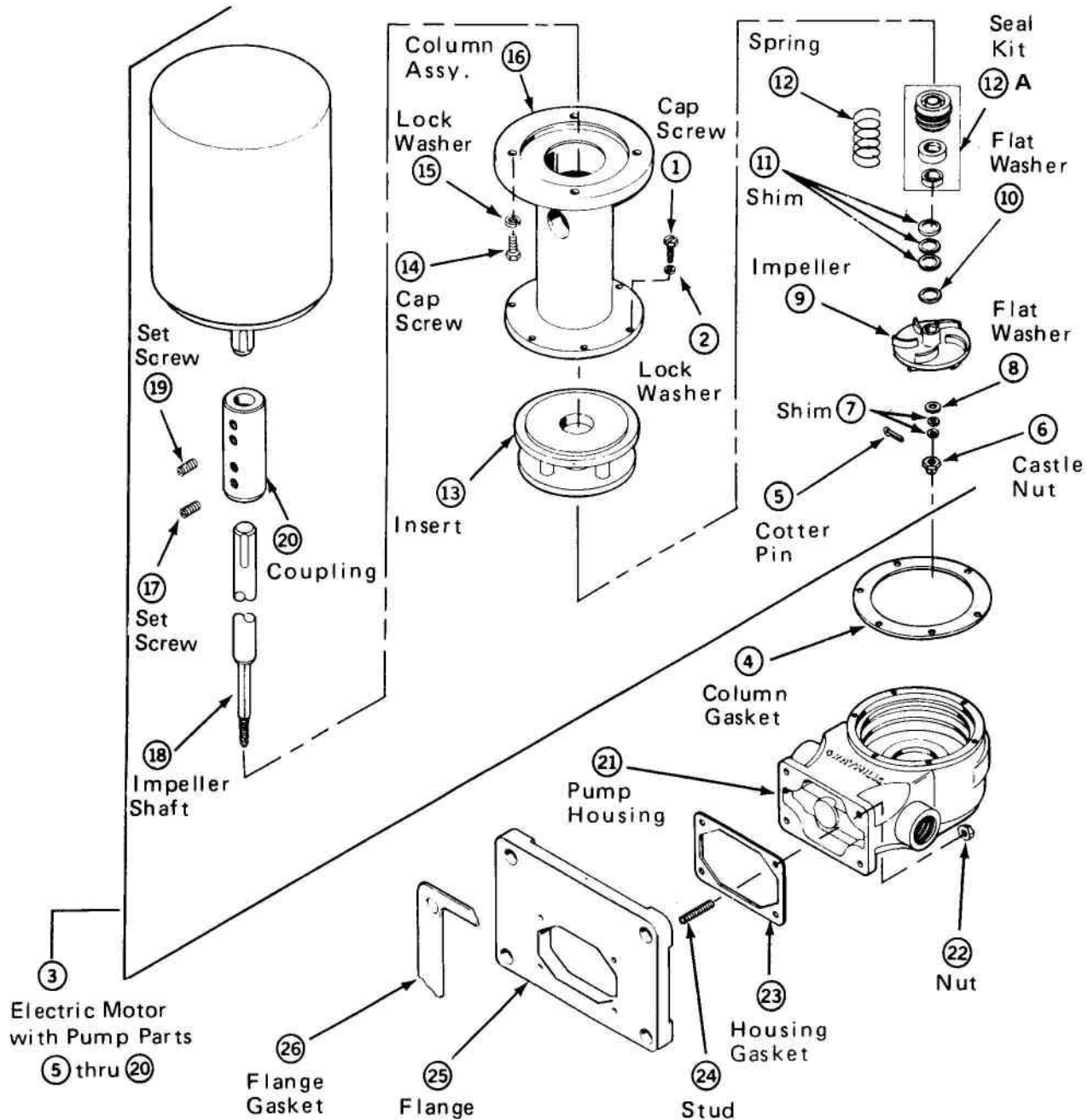

REPLACEMENT PARTS LIST

Ref. No.	Part No.	Part Name	Pump Model No.
12a	745-03969	Seal Kit	(All)
4	744-06608	Gasket, column	(BSW/S & CSW/S)
4	744-06607	Gasket, column	(DSW/S & ESW/S)
23	744-06610	Gasket, housing	(BSW/S & CSW/S)
26	744-06611	Gasket, flange	(CSW/S & DSW/S)
26	744-06853	Gasket, flange	(ESW/S)

NOTE: For ordering of parts not listed, call Graymills direct (773) 248-6825 or FAX (773) 477-8673 with model number of pump.

MAINTENANCE: KEEP PUMP & CONTAINER CLEAN

Any coolant system used with machine tools accumulates deposits of metallic chips, grinding dust, and sediment. For this reason, the container of your coolant systems should be cleaned periodically to prevent damage to the pump and motor and to provide clean liquid for application.

Do not restrict the vents if an open motor is used and keep oil and chips from accumulating around the motor.

Graymills Centrifugal pump motors do not require lubrication. Pumps furnished with non standard motors requiring lubrication have instructions on motor.

If pumps are used with liquids, like adhesives, or abrasive slurries or inks, make sure that they are flushed with the proper solvent after using. Keep solvents or cleaners away from the motor, lower motor bearing and wiring.

WHAT TO CHECK IF FLOW IS REDUCED BELOW RATED OUTPUT

1. Catalog information gives the rated delivery of this pump. If there is any question about flow rate refer to the catalog.
2. Check the intake to make sure nothing is blocking the entrance of liquid into the pump.
3. Check hoses to make sure there is no crimping or unusual restriction.
4. Check the viscosity of liquid. The heavier the viscosity the less the flow.
5. Check the voltage and cycle. (Low voltage will cause a reduction in RPM).
6. Check rotation of motor if a 3 phase motor is used.
7. Make sure the pump impeller section is immersed in the liquid.
8. Check for binding within the body of the pump caused by rags, strings, or chips.
9. Make sure pump intake is not in the sludge, slurry, or is not directly on the bottom of the container which will restrict the intake.

HOW TO ORDER PARTS

Give model number of pump. If model number cannot be determined, the motor serial number, horsepower, speed and type will help. Approximate date of purchase will also help.

Give serial or lot number of pump.

WARRANTY

Graymills Corporation warrants that the equipment manufactured and delivered, when properly installed and maintained, shall be free from defects in workmanship and will function as quoted in the published specification. **Graymills** does not warrant process performance, nor assume any liability for equipment selection, adaption, or installation.

Warranty does not apply to damages or defects caused by shipping, operator carelessness, misuse, improper application of equipment which damages or impairs the proper function of the unit, and modifications made to the Unit. Warranty does not apply to expendable parts needing replacement periodically due to normal wear and tear.

A new Warranty period shall not be established for repaired or replaced materials or products. Such items shall remain under Warranty for only the remainder of the Warranty period of the original material or product.

THE FOREGOING WARRANTIES ARE IN LIEU OF ALL OTHER WARRANTIES, WHETHER ORAL, WRITTEN, EXPRESSED, IMPLIED OR STATUTORY. **GRAYMILLS CORPORATION** MAKES NO OTHER WARRANTY OF ANY KIND, EXPRESS OR IMPLIED. ALL IMPLIED WARRANTIES OR MERCHANTABILITY AND FITNESS FOR A PARTICULAR PURPOSE WHICH EXCEED THE AFORESTATED OBLIGATION ARE HEREBY DISCLAIMED BY **GRAYMILLS CORPORATION** AND EXCLUDED FROM THIS SALE. **Graymills** warranty obligations and Buyer remedies (except to title), are solely and exclusively stated herein. In no case will Graymills be liable for consequential damages, loss of production, or any other loss incurred due to interruption of service.

Graymills' obligation under this Warranty shall be limited to:

- (a) Repairing or replacing (at **Graymills** sole discretion), any non-conforming or defective component within one year from the date of shipment from **Graymills**.
- (b) Repairing or replacing (at **Graymills** sole discretion), components supplied by, but not manufactured by **Graymills**, to the extent of the warranty given by the original manufacturer.

Buyer must give **Graymills** prompt notice of any defect or failure.

If you believe you have a Warranty claim, contact **Graymills** at (773) 248-6825. Any return material must have an RMA number on the package and shipping prepaid or shipment will be refused. **Graymills** will promptly examine the material and determine if it is defective and within the Warrant period.

It is the responsibility of our customers to report damage in shipment. This damage must be reported to the carrier who delivered the equipment, and claims must be filed by the customer. Any other failure on the part of this equipment to operate properly for reasons other than shipping damage should be reported directly to the distributor from whom you purchased the equipment. Always state the correct serial number, model number, and the date purchased.